

LANE TECH SHEET

EZ LIFT PINS

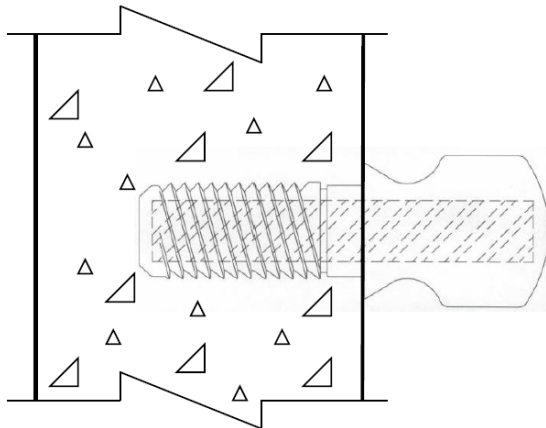
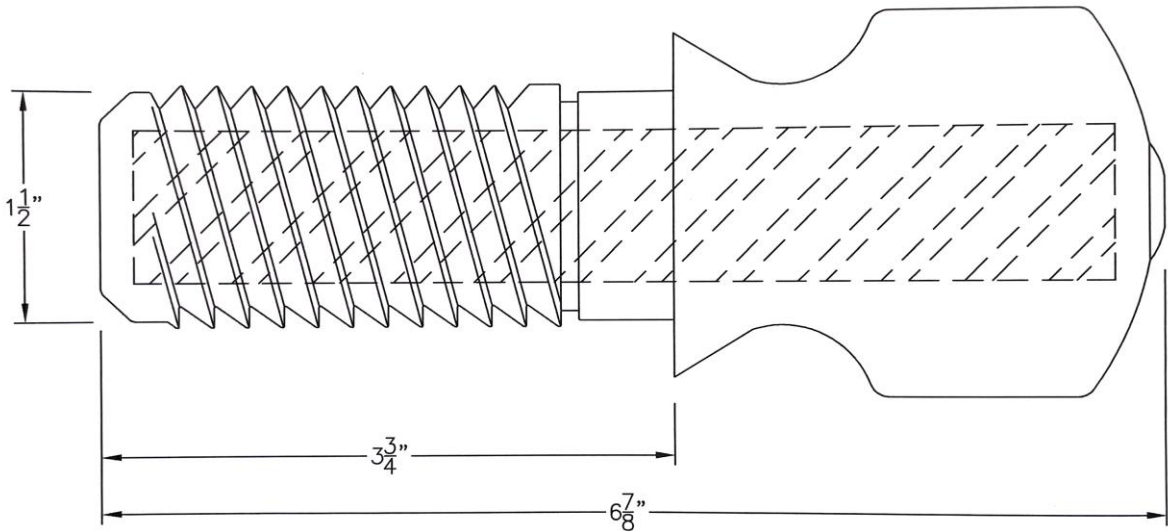

Load Capacity:

The *working load limit* is 4,000 lbs. per pin*

* Ultimate load is four times the working load.

Pin Composition:

Each pin is injection molded polypropylene around a 1-1/8" diameter ASTM A-615 Grade 60 reinforcing bar. The polypropylene material conforms to ASTM D-4101 specifications.



Drawing: 1
Scale: None

EZ LIFT PINS
4,000 lb. working load
Part # EZ-4000

LANE INTERNATIONAL CORPORATION

P.O. Box 925 * Tualatin, OR 98062
503-692-9860 * www.laneinternational.com